

GPA-H Series

Energy-saving Circulating Pump

Installation and Operating Instruction



Hefei Xinhoo Canned Motor pump Co., Ltd

DIRECTORY

Precautions for use of products.....	3
1.Basic Product Parameters.....	5
1.1Product Model Description.....	5
1.2Application scope.....	5
1.3Product Certification.....	5
1.4Basic Product Parameters.....	5
2.Product application conditions.....	6
2.1Media requirements.....	6
2.2Comparison Table of Water Temperature and Inlet Pressure.....	6
2.3Service environment requirements.....	6
2.4Storage environment requirements.....	6
2.5Liquid temperature and Ambient temperatureComparison Table.....	6
3.Product operation instructions.....	7
3.1Product installation direction diagram.....	7
3.2Adjustment of outlet box position.....	8
3.3Electrical connection.....	9
3.4Illustration of insulation cotton wrapping	9
4.Explanation of panel display diagram.....	10
5.Electric control instructions.....	12
5.1Signal control principle.....	12
5.2Signal connection.....	13
5.3PWMsignal input.....	14
5.4PWMfeedback.....	16
6.Start up.....	18
6.1Before start up.....	18
6.2Start and stop of pump.....	18
6.3Surge current.....	18
7.Performance curve.....	19
8.Description of nameplate.....	20
9.Fault checklist.....	21
Annex.....	22
a.Installation dimension drawing.....	22
b.Power interface.....	23
c.Recycling.....	24
d.Delivery Attached Documentation.....	24
Product warranty book of Hefei Xinhoo.....	25

PRECAUTIONS FOR USE OF PRODUCTS

- 1.The installation manual should be read carefully before installation and use.
- 2.Any failure to comply with the content marked by safety warning marks may cause personal injury, pump damage and other property loss, for which, the manufacturer shall not assume any responsibility and compensation.
- 3.Installer, operator and user must comply with the local safety regulations.
- 4.The user must confirm that installation and maintenance of the product should be conducted by staff proficient in the instructions and having professional qualification certificates.
- 5.Pumps must not be installed in damp environment or places that may be splashed by water.
- 6.The power supply of pump should be cut off during installation and maintenance.
- 7.The heat feed pipeline should not be supplemented with non-softened water frequently to avoid an increase in the calcium in the circulating water of pipeline so as not to clog impellers.
- 8.It is prohibited to start the pump when there is no pumping liquid.
- 9.Pumping liquid may be of high temperature and pressure, therefore, liquid in the system should be drained off or stop valves on both sides of the pump must be switched off to avoid burns before moving and removing pump.
- 10.In the winter, if the pump system does not operate or when the ambient temperature is below 0°C, liquid in the pipeline system should be emptied to avoid causing frost crack to the pump body.
- 11.If the pump does not use for a long time, please turn off the conduit valves on pump inlet and outlet ends and cut off the power of pump.
- 12.If the flexible cord is damaged, please connect service center to have it replaced together with the connector.

13.If it is found that the motor is burning hot and abnormal, immediately turn off the valve on the pump inlet end and cut off the pump power, besides, immediately contact your local dealer or service center.

14.If the pump failure can not be cleared in accordance with the description in the instructions, immediately turn off the valve on the pump inlet end and cut off the pump power, besides, immediately contact your local dealer or service center.

15.The product should be placed out of the reach of children, after installation, isolation measures should be taken to prevent children from touching.

16.The product should be placed in a dry, ventilated and cool place and stored at room temperature.

17.This appliance can be used by children aged from 8 years and above and persons with reduced physical, sensory or mental capabilities or lack of experience and knowledge if they have been given supervision or instruction concerning use of the appliance in a safe way and understand the hazards involved. Children shall not play with the appliance. Cleaning and user maintenance shall not be made by children without supervision.

**Warning**

Before starting installation, the Installation and Operating Instructions of device must be read carefully. Installation and use of the device must comply with local regulations and follow good operation specification.

**Warning**

Personnel with physical decline, dysesthesia or poor mental ability and lacking of experience and relevant knowledge (including children) should use the pump under the supervision and guidance of people who can take charge of their safety.

SYMBOL DESCRIPTION**Warning**

Failure to comply with this security declaration will likely result in personal injury!

Caution

Failure to comply with this security declaration will likely cause failure or damage to the equipment !

Note

Notes or instructions facilitating the work and ensuring operational safety.

1. BASIC PRODUCT PARAMETERS

1.1 Product series code

The model of electric pump is composed of capital Latin script and Arabic numerals, and its meaning is as follows:

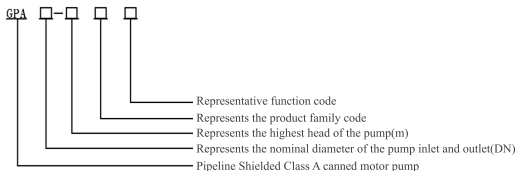

Model example: GPA25-17 H indicates that the inlet and outlet diameter of the circulating pump is DN25, the maximum head is 17 m, and the series of pump is used for heating pump.

1.2 Application scope

Heating pump dual supply system, Underfloor heating mixed water system, Heating pump hot water system, HVAC, Boiler system, and other heating and cooling occasions.

Suitable for refrigerants such as R290.

1.3 Product Certification

The product meets the certification requirements of EEI TUV EMC RoHS REACH CE GS UKCA LVD (Specific certification based on applicable region)

1.4 Basic Product Parameters

Model	voltageV/Hz	Current A	Max flow m ³ /h	Max head m	Rated Flow m ³ /h	Rated head m	Max power W	EEI
GPA25-6H	220-240 50/60	0.35	3.2	6	2	3.3	39	≤0.20
GPA25-7H		0.45	3.4	7	2.2	3.8	52	≤0.20
GPA25-7.5H		0.5	3.8	7.5	2.5	4.7	60	≤0.20
GPA25-9H		0.9	4.5	9	2.5	6.5	95	≤0.21
GPA25-11H		1.09	5.5	11	3.5	7.5	140	≤0.21
GPA25-13H		1.5	6	13	3	12	250	≤0.23
GPA25-15H		1.9	7	15	5	11	300	≤0.23
GPA25-17H		2.5	7.5	17	5	13	350	≤0.23

Rated voltage: 220-240VAC	Degree of protection: IP44	Insulation level: H
Temperature class: TF95	Noise: <45dB (A)	Standby power: ≤3W
Surge current: <10A	Turning direction: clockwise when viewed from the impeller inlet	
EMC standards EN61000-6-1 与 EN61000-6-3		

2.PRODUCT APPLICATION CONDITIONS

2.1 Media requirements

Medium: water or water + glycol (≤50%) mixture	Medium temperature: -20℃~95℃
PH value of medium: 6.5~8.5	Medium hardness: ≤25°dH
Content of solid impurities in medium: diameter and length direction of solid impurities ≤ 0.1mm, and volume ratio ≤ 0.1%.	

2.2 Comparison Table of Water Temperature and Inlet Pressure

To avoid damage to pump bearings caused by cavitation noise, the following minimum pressure should be maintained at the pump inlet:

Liquid temperature	<50℃	95℃
Inlet pressure	0.1bar	0.5bar
	1m head	5 m head

2.3 Service environment requirements

Usage: keep the shaft horizontal	Altitude: < 1000m
Operating ambient temperature: -30℃~ 55 ℃ (there is no freezing in the pipeline and water pump)	Operating ambient humidity≤95%

2.4 Storage environment requirements

Storage ambient temperature: - 30 ℃~ 70 ℃ (there is no freezing in the pipeline and water pump)	Humidity of storage environment: ≤95%
--	--

2.5 Liquid temperature and Ambient temperature Comparison Table

Ambient temperature (°C)	Liquid temperature
	Maximum (°C)
0	95
10	95
20	95
30	95
35	90
40	70
55	65

In domestic hot water, it is recommended to keep the temperature of water below 65 °C so as to reduce scaling

3.PRODUCT OPERATION INSTRUCTIONS

3.1 Product installation direction diagram

When the circulation pump is installed, the circulation pump shaft should be in a horizontal position, and the allowable installation angle of the circulation pump shaft is $\pm 5^\circ$. The installation method of the circulating pump in the system should ensure that there is no large amount of gas in the chamber of the circulating pump to avoid affecting the normal operation of the circulating pump.

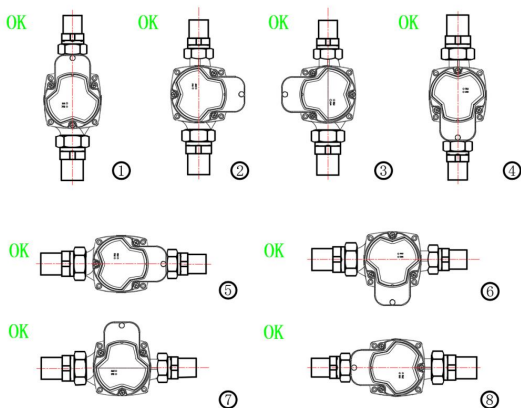

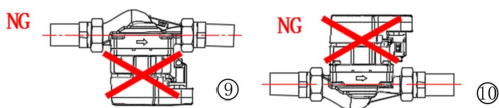

3.2 Adjustment of outlet box position

Junction box can rotate in 90°. To change the position of junction box, follow the operating steps below:

- (1) Switch the valves of inlet and outlet and conduct decompression;
- (2) Loosen and remove the four socket head cap screws that fix the pump body;
- (3) Rotate the motor to the desired position and match the four screw holes;
- (4) Put the four socket head cap screws back and tighten them in the cross direction order;
- (5) Open the valve of inlet and outlet.

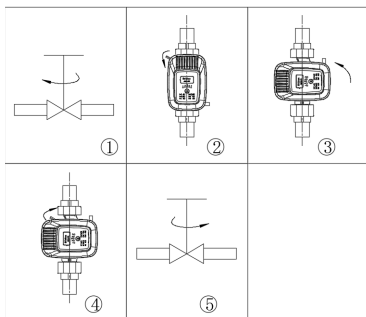

Warning



Pumping liquid may be of high temperature and pressure, therefore, liquid in the system should be drained off or valves on both sides of the pump must be switched off before removing socket head cap screws.

Caution

Change the position of junction box, the pump should not be started until the system has been filled with pumping liquid or valves on both sides of the pump are open

3.3 Electrical connection

Electrical connection and protection should be carried out in accordance with local regulations.

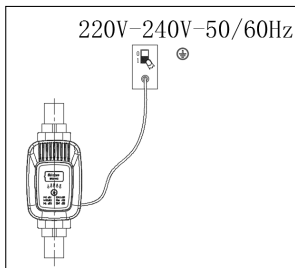

Warning

The electric pump must be connected to earth wire . 

The pump must be connected with an external power switch; the minimum gap Between all the electrodes is 3 mm.

- circulating pump does not need external motor protection.
- Check whether the voltage of power supply and frequency match with the parameters marked by pump name-plate.
- Use the pump associated plug to connect power supply.
- If the indicator lamp on the control panel lights, it indicates that the power supply is switched on.



3.4 Illustration of insulation cotton wrapping (pay attention to the location of the wrapping)















Note

Be careful not to block the drainage hole during installation

4.EXPLANATION OF PANEL DISPLAY DIAGRAM

PWM1 control S1 function		
The comparison table between The working status of the circulating pump and the light on is as follows		 <p>Operation indicator</p>
Lighting area	explain	Illustration
MAX	Constant speed operation	
PWM	Running in PWM control mode	

Note: The PWM1 (S1 function) control and PWM2 control mode are generally a combination of MAX + PWM

PWM1 control S3 function			
Press the button briefly once to switch the working mode. The default working mode when powered on is HS3 mode or Auto. The comparison table between the number of button presses and the working gear of the water pump is shown in the following table			
		 <p>Operation indicator</p> <p>Button</p>	
Number of buttons pressed	Lighting area	illustrate	illustration
0	HS3	Constant speed 3rd gear	
1	AUTO	Automatic adaptation	
2	BL1	Proportional pressure 1st gear	
3	BL2	Proportional pressure 2nd gear	
4	BL3	Proportional pressure 3rd gear	
5	HD1	Constant pressure 1st gear	
6	HD2	Constant pressure 2nd gear	
7	HD3	Constant pressure 3rd gear	
8	HS1	Constant speed 1st gear	
9	HS2	Constant speed 2nd gear	
/	P	PWM control	

Note: PWM1(S3 function) control are generally a combination of 10 gear + PWM

Fault code display status

After the power is turned on, the gear indicator light corresponding to the gear light remains on.

If the electric pump cannot operate normally, all gear indicator lights will continue to flash, and the corresponding fault display is as follows:

<p>1. Overvoltage protection: When the input voltage is detected to be higher than the protection voltage, it enters overvoltage protection after 2 seconds. All indicator lights flash once, and the water pump stops running. When the voltage returns to normal, the water pump resumes normal operation.</p>
<p>2. Undervoltage protection: When the input voltage is detected to be lower than the protection voltage, it enters undervoltage protection after 2 seconds. All indicator lights flash twice, and the water pump stops running. When the voltage returns to normal, the water pump operates normally.</p>
<p>3. Overcurrent protection: When the electric pump is running at full load, if there is hardware overcurrent, turn on overcurrent protection. When overcurrent occurs, the water pump immediately stops working, all indicator lights flash 3 times, and the water pump restarts after 8 seconds. If the fault is not eliminated, it will continue to cycle.</p>
<p>4. Phase failure protection: When the motor is detected to be out of phase during startup, all indicator lights flash 4 times. The water pump immediately stops working. After 8 seconds, the water pump restarts. After the cumulative number of protection times reaches 5, the water pump is completely protected and will no longer restart. It needs to be powered on again.</p>
<p>5. Stall protection: When the water pump is running and it is detected that it is stuck, the controller will trigger a lock rotor protection. All indicator lights will flash 5 times, and the water pump will stop working. After 8 seconds, the water pump will restart. If the fault is not eliminated and the cumulative number of protection times reaches 5, the water pump will be completely protected and will no longer restart. It is necessary to power on again.</p>
<p>6. Light load protection: When the water pump is running, it is detected that the water pump is running without water for more than 8 seconds. Light load protection is activated, and all indicator lights flash 6 times. After 8 seconds, the water pump restarts. After the cumulative number of protection times reaches 5, the water pump is completely protected and will not restart again. It needs to be powered on again.</p>
<p>7. Over temperature protection: When the surface temperature of the IPM module is higher than $125 \pm 10\%$ °C under rated voltage, frequency, and high-temperature environment, the water pump stops and all indicator lights flash 7 times simultaneously. When the surface temperature of the IPM is below $100 \pm 10\%$ °C, the water pump returns to normal operation.</p>
<p>8. Overheating treatment: The water pump is in a reduced power operation state. When the surface temperature of the IPM module is higher than $115 \pm 10\%$ °C under rated voltage, frequency, and high-temperature environment, the water pump will operate at reduced power. If the temperature is lower than $100 \pm 10\%$ °C, the water pump will resume normal operation.</p>

If there is a fault display, the power supply must be disconnected for troubleshooting. After troubleshooting, reconnect the power supply and start the electric pump.

5.ELECTRIC CONTROL INSTRUCTIONS

5.1 Signal control principle

The control method of the electric pump is controlled by a modulated low-voltage PWM (pulse width modulation) digital signal, that is, the change in speed depends on the external

input signal. The change in speed is one of the input control functions:

Digital Low Voltage Pulse Width Modulation Signal:

Design frequency range of square wave PWM signal: 100Hz~4000Hz;

PWM input signal (PWM IN) is used to give a speed command, and t adjusts the speed command by adjusting the PWM duty cycle;

The PWM output signal (PWM OUT) is the feedback signal of the pump, the PWM frequency is fixed at 75Hz, the collector open drain output must be connected to a Pull-up resistor, the voltage range is 5-32V DC, and it is recommended to use 5V DC.

PWM input signal	parameter
Current isolation in pump	YES
Frequency input	100 – 4000 Hz
Input voltage high level	4.0 – 24 V
Input voltage low level	≤ 0.7V
Input current high level	Max 10 mA@100Ohms
Input PWM duty cycle	0 – 100 %
Signal polarity	Fixed changeless
Rise time	≤ T/1000

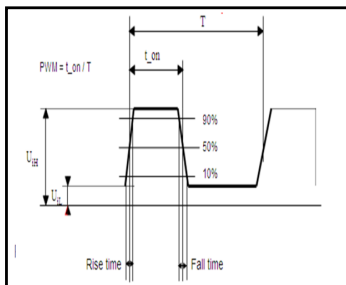

5.2 Signal connection

The water pump is controlled by external electronic components through an interface. The interface converts external signals into signals that the microprocessor on the water pump can recognize. In addition, when the water pump inputs 230V voltage, the interface can ensure that the user does not have a risk of high voltage electric shock when touching the signal line.

The corresponding functions of signal wire colors are as follows: input wire (red), feedback wire (green), and grounding wire (yellow)

Note “Signal Ref” is a reference ground that is not connected to a protective ground.

PWM Input signal interface circuit

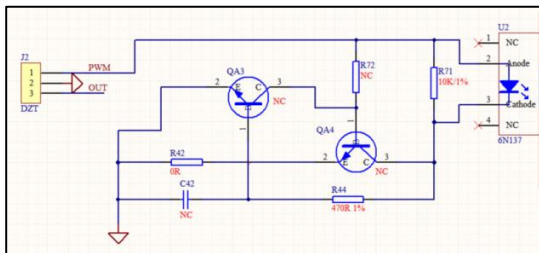

PWM Output signal interface circuit

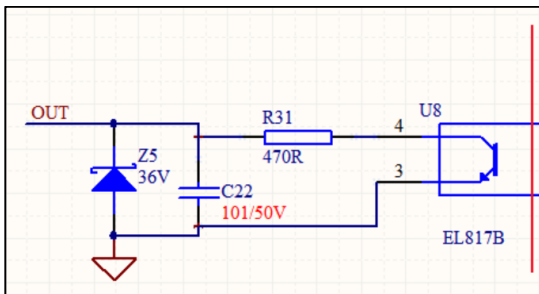

5.3 PWM signal input

PWM 1 control S1 function		
Under fixed frequency, different duty cycles correspond to different motor given speed signals. Inverse proportional control mode is adopted. The specific control logic is as follows:	PWM input signal (%)	Pump status
<p>When the PWM signal is less than 5%, the water pump operates at the highest speed. At this time, circulating pump is Operating in the maximum power and maximum head</p>	0	When the pump is switched to non PWM mode (maximum speed operation), the system has no PWM signal by default
	≤ 5	The pump operates at max speed
	$> 5 \sim \leq 85$	Pump linearity from highest to lowest
	$> 85 \sim \leq 88$	The pump operates at the lowest speed
	$> 88 \sim < 93$	If the input signal fluctuates near the speed change point, the starting and stopping of the water pump will be prevented according to the hysteresis principle
	$\geq 93 \sim \leq 100$	Standby, the water pump stops running
	Recognition accuracy	± 1 (Example: When the PWM input signal is 20%, the actual duty cycle is in the range of 19% ~21%)

PWM 1 control S3 function		
Under fixed frequency, different duty cycles correspond to different motor given speed signals. Inverse proportional control mode is adopted. The specific control logic is as follows:	PWM input signal (%)	Water pump status
<p>When the PWM signal is less than 10%, the water pump operates at the highest speed. At this time, circulating pump is Operating in the maximum power and maximum head</p>	0	When the pump is switched to non PWM mode (max speed operation), the system has no PWM signal by default
	≤ 10	The pump operates at max speed
	$> 10 \sim \leq 84$	Pump linearity from highest to lowest
	$> 85 \sim \leq 90$	The pump operates at the lowest speed
	$> 91 \sim < 95$	If the input signal fluctuates near the speed change point, the starting and stopping of the water pump will be prevented according to the hysteresis principle
	$\geq 96 \sim \leq 100$	Standby, the pump stops running
	Recognition accuracy	± 1 (Example: When the PWM input signal is 20%, the actual duty cycle is in the range of 19% ~21%)

PWM 2 Signal Control		
<p>Under fixed frequency, different duty cycles correspond to different motor given speed signals. Inverse proportional control mode is adopted. The specific control logic is as follows:</p> <p>When the PWM signal is more than >95%, the water pump operates at the highest speed. At this time, circulating pump is Operating in the maximum power and maximum head .</p>	PWM input signal (%)	Water pump status
	0	Standby, the water pump stops running
	≤ 7	Standby, the water pump stops running
	$> 7 \sim < 12$	If the input signal fluctuates near the speed change point, the starting and stopping of the water pump will be prevented according to the hysteresis
	$\geq 12 \sim < 15$	The water pump operates at the lowest speed
	$\geq 15 \sim < 95$	Pump linearity from highest to lowest
	$\geq 95 \sim \leq 100$	The water pump operates at maximum speed
Recognition accuracy	± 1 (Example: When the PWM input signal is 20%, the actual duty cycle is in the range of 19% ~21%)	

In the high duty cycle region of the PWM1 control signal and the low duty cycle region of the PWM2 control signal, if the input signal fluctuates at the critical point, there is a hysteresis region to prevent frequent pump starts and stops.

In the low duty cycle area controlled by the PWM1 signal, the pump operates at high speed for system safety reasons. Example: In the event of a damaged signal cable in the heat pump system, the pump will continue to operate and transfer heat through the main heat exchanger at maximum speed to ensure system safety

Under the control of PWM2 signal, the pump stops running when there is no signal, which is for system safety reasons. Example: In the event of a damaged signal cable in the solar system, the circulating pump will shut down and stop transferring heat through the main heat exchanger to ensure system safety

When PWM input signal is 0%, the pump will switch to non-PWM mode (normal mode), and the default system will have no PWM signal input.

Note

This system is adaptive to the automatic switching of PWM and non-PWM mode. When there is PWM signal input, the system will enter PWM mode.

5.4 PWM feedback

PWM feedback signal can provide operation status of the pump, such as power/flow or all kinds of alarm/warning modes.

PWM feedback signal will feed back exclusive alarming information. If the power voltage detects under voltage signal values, its output signal will be set to 75%. Provided sundries settlement exists in the hydraulic system and causes rotor being blocked, the alarm will be given higher priority.

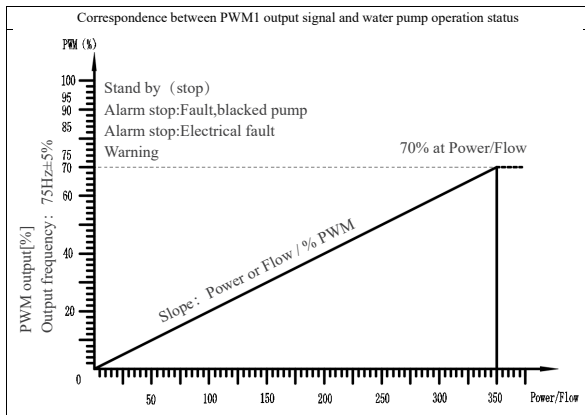

0-70	The circulating pump works normally	/
75	Abnormal working mode, circulation pump shutdown	The circulating pump is in an overvoltage or undervoltage state
85	Abnormal working mode, circulation pump shutdown	The circulating pump is in a Overcurrent Phase failure Light load and over temperature protection state Note: After a fault occurs, PWM feedback needs to be maintained until the fault condition is resolved. For example, after a blocked rotor fault occurs in the circulating pump, the pump continuously provides feedback on a 90% duty cycle until the blocked rotor fault is resolved..
90	Permanent shutdown of the circulating pump	The circulating pump is in a Stall protection protection
95	Standby	The circulating pump stop work

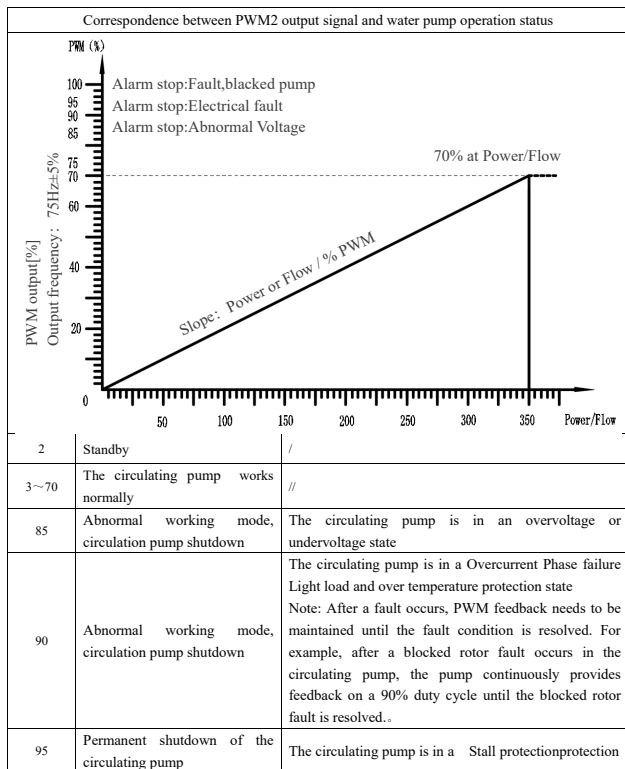

6.START UP

6.1 Before start up

Before starting the electric pump, make sure that the system is filled with liquid, gas has been vented, and the electric pump inlet pressure must achieve the minimum inlet pressure as required (see Chapter 2.2).

Caution

The pump should not operate without water.

6.2 Start and stop of pump

Startup time: the starting time of the water pump is less than 10S, that is, the time from power on to reaching the maximum speed

In PWM mode, when starting from the stop state of the pump (without power supply), 90% of the maximum speed must be reached in at least 10 seconds

In PWM mode, start from standby mode and reach 90% of the max speed in at least 10s

Shutdown time: the shutdown time of the water pump is less than 1s, that is, the time from power failure to shutdown of the water pump (with PWM model)

6.3 Surge current

Test conditions:	Surge current	Duration
T=20±5°C	<10A (Cold)	<4ms

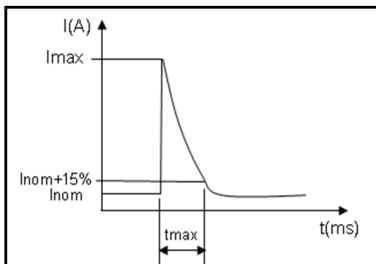

7.PERFORMANCE CURVE

Testing liquid: gas-free water.

Applicable density of curve $\rho = 983.2 \text{ kg/cubic meter}$, and the liquid temperature is $+25^{\circ}\text{C}$.

All the values expressed by curves are averages, they can not be taken as the guaranteed curves. If a particular performance is required, measurement must be conducted separately.

Applicable kinematic viscosity of curve $\nu = 0.474 \text{ mm}^2 / \text{s}$ (0.474CcST)

This performance curve is suitable for normal temperature water, such as pump for non-water medium, the hydraulic performance of the pump will be reduced, therefore, in the selection of pump, must consider the characteristics of the liquid medium.

The following curve only includes the maximum range curve of the product

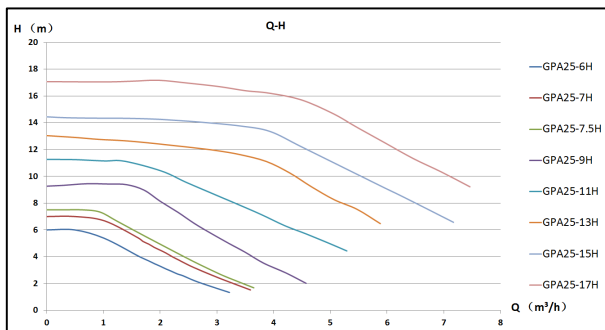

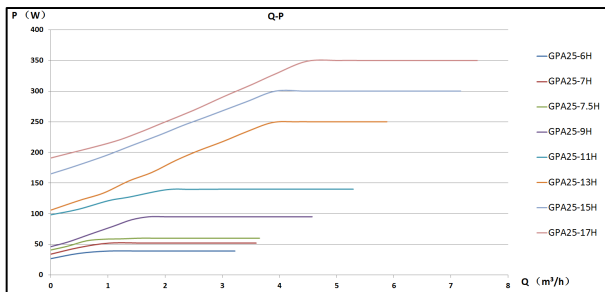

8. DESCRIPTION OF NAMEPLATE

6	220-240V AC/50/60 Hz	10		Max	Min
7	Class H TF 95	11	P1 (W)	140	6.6
8	IP44 EEI ≤ 0.21-Part 3	12	I (A)	1.09	0.08
9			MPa	1.0	
	Hefei Xinhoo Canned Motor Pump Co.,Ltd		NO:1903190001		
	No.1 Yanglin Road, Hi-tech Development Zone, Hefei, Anhui, China				

NO.	Explanation	
1	Power	Maximum mode maximum power
		Minimum mode minimum power
2	Current	Maximum mode maximum current
		Minimum mode minimum current
3	Maximum pressure-bearing of system (MPa)	
4	Product No.	
5	Motor steering	
6	Voltage (V)	

NO.	Explanation
6	Voltage (V)
7	Insulation class
8	Protection Lever
9	Certification mark
10	Frequency (Hz)
11	Temperature grade
12	Energy efficiency label
13	Model

9. FAULT CHECKLIST



Warning

Before carrying out any maintenance and repair to the electric pump, make sure the power is disconnected and will not be accidentally switched on.

fault	Cause of occurrence	Exclusion method
Circulating pump cannot start	Whether the power supply is disconnected and the voltage is normal	Check the power connection and determine the voltage
	The fuse in the device is burnt out	Replace the fuse
	Current/current controlled circuit breaker disconnection	Connect the circuit breaker
	Circulating pump malfunction	Replace the circulating pump
	Voltage too low	Check if the power supply is within the specified range
	Circulating pump blocked (stuck)	Remove impurities
Water pump running but no pressure	The inlet and outlet valves are closed or there is no water in the system	Open the valve or add liquid
	Air in water pump and Plumbing	Run for a while after exhaust

fault	Cause of occurrence	Exclusion method
There is noise in the circulating pump	There is gas in the circulating pump	System exhaust
	There are impurities and friction in the pump	Clean
	Wear of wiping ring, wiping screen sleeve or bearing mechanical seal	Replace the circulating pump
	Water pump cavitation	Reduce the outlet valve or increase the inlet pressure
Insufficient traffic	The performance of the circulating pump is too low	Selection of high-power circulating pumps
	Pipeline blockage	Clean the pipeline and filter
The circulation pump cannot be controlled	No signal on the signal line	Poor cable contact, reinstall or replace

ANNEX

a. Installation dimension drawing

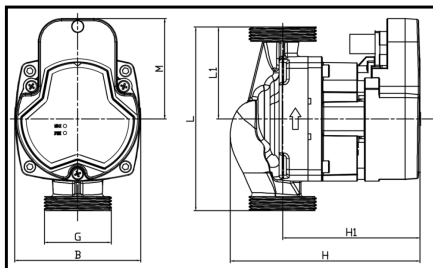

Model	G	B	M	L	LI	H	HI
GPA20-XH/130	G1 ^φ	90	71	130	65	135	98
GPA25-XH/130	G1 1/2 ^φ	90	71	130	65	135	98
GPA25-XH/180	G1 1/2 ^φ	90	71	180	90	135	98
GPA32-XH/180	G2 ^φ	90	71	90	90	135	98

This table is applicable to GPAxx-6H GPAxx-7H GPAxx-7.5H GPAxx-9H

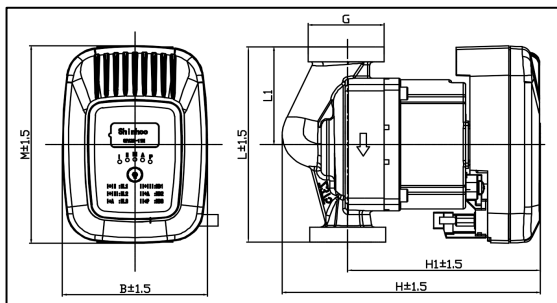

Model	G	B	M	L	L1	H	H1
GPA25-11H/130	G1 1/2"	91	131.5	130	65	162.5	121.5
GPA25-11H/180	G1 1/2"	91	131.5	180	90	162.5	121.5
GPA32-11H/180	G2"	91	131.5	180	90	162.5	121.5

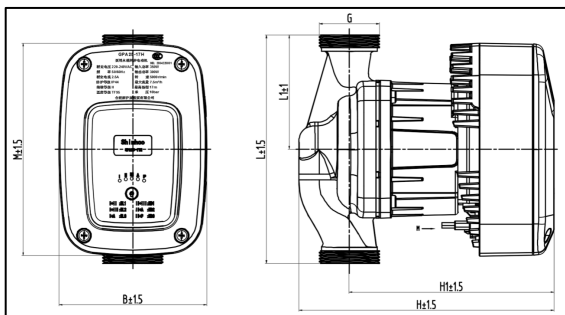

Model	G	B	M	L	L1	H	H1
GPA25-15H/180	G1 1/2"	117	168	180	90	201.5	162
GPA32-15H/180	G2"	117	168	180	90	201.5	162
GPA25-17H/180	G1 1/2"	117	168	180	90	201.5	162
GPA32-17H/180	G2"	117	168	180	90	201.5	162

b. Power interface

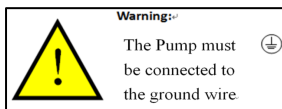
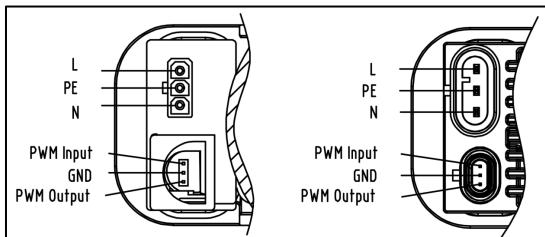

c. Recycling



The meaning of the lined wheel trash can:

Do not treat electrical appliances as unclassified urban waste and use separate collection facilities+ Please contact the local government to obtain information about the existing collection system.

If electrical appliances are discarded in landfills or landfills, harmful substances may leak into groundwater and enter the food chain, damaging your health and well-being.

When replacing old equipment with new equipment, retailers have a legal obligation to take back your old equipment for disposal, at least for free.

d.Delivery Attached Documentation

Quality Assurance Card			
Model		Circulation Pump	
Type		Serial No.	
Invoice No.		Purchase Date	
Installation			
Distributor			
Dealer		To be valid with dealer's stamp	
User's information			
Name			
Address			
Post Code			
Phone No.			

Certificate of Approval	
Model	Circulation Pump
Type	
QA	
Manuf.Date	

Encasement Bill		
Model		Circulation Pump
S/N	Appellation	Quantity
1	Circulation Pump	1
2	Pipe Joint	2
3	Tube Nut	2
4	Seal ring	2
5	Instruction Manual	1
Case No.		Packing Date

PRODUCT WARRANTY BOOK OF HEFEI XINHU

Hefei Xihu Canned Motor pump Co., Ltd provides 12 months' quality assurance for the products since the sales date, and shall be responsible for the product failure or damage caused by manufacturing and material defects. The warranty is on condition that the installation of product should be in line with Xihu Installation and Use Manual and recognized good operation specification.

This warranty does not apply to the product failure or damage caused by

- ② use the product other than for the usage recommended by Xihu;
- ② misuse of the product that does not conform to Xihu Installation and Use Manual;
- ③ improper maintenance and handling of product;
- ③ disassemble products and replace parts by oneself.

Any product provided rather than manufactured by Hefei Xihu Canned Motor pump Co., Ltd should comply with the quality assurance provisions of the manufacturer.

Within warranty period, the product repair is guaranteed by purchase invoice and warranty bill. Please send or return the product in need of repair to the local dealer of Hefei Xihu Canned Motor pump Co., Ltd. or designated maintenance point for repair. Hefei Xihu Canned Motor pump Co. may determine whether home maintenance service shall be provided for free in accordance with its maintenance policies in the local. Guarantee repair of parts is free.

Hefei Xihu Canned Motor pump Co., Ltd. will not accept claims to damage which should be borne by a third party or caused by product failure of any other company.

Hefei Xihu Canned Motor pump Co., Ltd shall not be responsible for the product failure or damage due to abnormal operating conditions, war, riot, wind (rain) storm, disaster or other force majeure.

Hefei Xihu Canned Motor pump Co., Ltd reserves the power of interpretation on the unaccomplished matter in the product warranty book.